

# Swimming Pool Rules and Regulations found in the Uniform Fire Prevention and Building Code (Uniform Code)

To all SNHA Rental Tenants and Homebuyers who are in the SNHA Renters and Homebuyers Programs. For those of you who wish to erect or construct swimming pools or wading pools on SNHA properties.

The limitations to construct or erect a swimming pools or wading pools, cannot be any more than 24 feet in diameter and no in-ground pools are allowed.

For swimming pools that hold 24 inches of water or more, there are certain restrictions and code compliance requirements that will be enforced by SNHA. Some of the key requirements that are listed more in detail are the following but not limited to: Barrier (Fence) Requirements, Entrapment Protection and Equipment Location & Clearances.

Wading pools that hold less than 24 inches of water are exempt from the above restrictions and code compliance requirements.

“NOTICE OF RISK” - Both swimming and wading pools can at times involve substantial risk of injury to self, others in the household, the community and other dangers. The tenant/homebuyer acknowledges that there are certain risks inherent in using swimming and wading pools and that the tenants’ or homebuyers assume all responsibility for the installation and use of the swimming and wading pools.

**PLEASE NOTE** that this is not intended to be the document required by Executive Law Section 376(6). This page includes a brief summary of some, but not all, of the Uniform Code’s requirements relating to swimming pools. For a more complete summary of those requirements, as well as a summary of the Uniform Code’s other pool-related requirements, please visit <https://www.dos.ny.gov/DCEA/currpoolreq.htm> for the document titled *Current Requirements for Swimming Pools Contained in the State Fire Prevention and Building Code* (UNIFORM CODE) [December 2010]. Visit <https://www.dos.ny.gov/DCEA/pdf/PoolsumUC0708.pdf> for a PDF version of the *Current Requirements* document.

## Definition of “Swimming Pool”

The term “swimming pool” is defined in the Uniform Code as “any structure, basin, chamber or tank which is intended for swimming, diving, recreational bathing or wading and which contains, is designed to contain, or is capable of containing water more than 24 inches (610 mm) deep at any point. This includes in-ground, above-ground and on-ground pools; indoor pools; hot tubs; spas; and fixed-in-place wading pools.”

**NOTE:** A pool which is capable of containing more than 24 inches of water is a “swimming pool” (and is subject to all applicable Uniform Code provisions relating to “swimming pools”) even if the pool is filled to a depth of less than 24 inches.

## Barrier (Fence) Requirements for Outdoor Residential Swimming Pools

### Brief Summary of Barrier Requirements for Outdoor Residential Swimming Pools:

An outdoor residential swimming pool must be provided with a barrier which completely surrounds the swimming pool and obstructs access to the swimming pool. The barrier may consist of a fence, a wall, a building wall, or any combination thereof. The barrier must be at least 4 feet (48 inches) high, and must satisfy certain specified requirements (which are discussed in more detail below).

Access gates must satisfy the requirements applicable to barriers, as well as certain additional requirements (which are discussed in more detail below). In addition, access gates must be securely locked with a key, combination or other child-proof lock sufficient to prevent access to the swimming pool through such gate when the swimming pool is not in use or supervised.

**NOTE:** In general, the barrier requirements discussed in this document apply to all swimming pools, without regard to the date of construction or installation of the pool.

**NOTE:** As mentioned above, the definition of "swimming pool" includes hot tubs and spas. However, a hot tub or spa with a safety cover that complies with reference standard ASTM F 1346, entitled Standard Performance Specification for Safety Covers and Labeling Requirements for All Covers for Swimming Pools, Spas and Hot Tubs, is exempt from the barrier requirements discussed here.

**NOTE:** The principal purpose of the Uniform Code's barrier requirements is to make swimming pools inaccessible to young children. The specific requirements discussed below are intended to prevent a child from crawling under the barrier, fitting through the barrier, or climbing over the barrier. The requirements for access gates are intended to prevent a child from opening an access gate.

**Barriers provided for outdoor residential swimming pools must satisfy the following requirements:**

- The barrier must completely surround the swimming pool and must obstruct access to the swimming pool.
- The barrier must be at least 4 feet (48 inches) high.
- The space between the bottom of the barrier and the ground cannot exceed 2 inches.
- In the case of an above-ground pool, the barrier may be at ground level or mounted on top of the pool structure; however, if the barrier is mounted on top of the pool structure, the space between the top of the pool structure and the bottom of the barrier cannot exceed 4 inches. See Figure 3109.4.1 on Page 3.
- Any opening in the barrier must be small enough to prevent the passage of a 4-inch-diameter sphere through the opening. See Figure 3109.4.1.1 on Page 3.

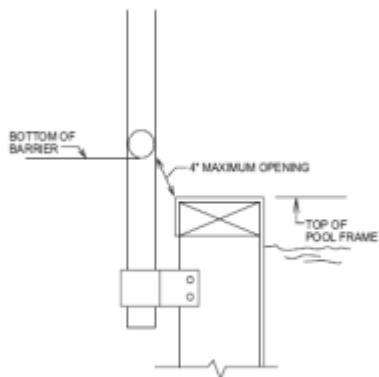

For St: 1 inch = 25.4 mm.

Figure 3109.4.1  
OPENING LIMITATIONS

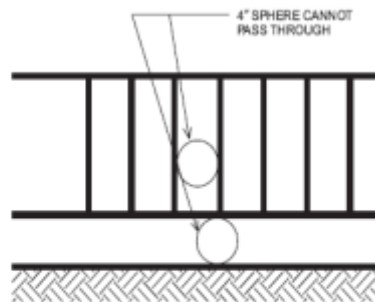

For St: 1 inch = 25.4 mm.

Figure 3109.4.1.1  
BARRIER OPENINGS

- A barrier that does not have openings, such as a masonry or stone wall, cannot contain indentations or protrusions (except for normal construction tolerances and tooled masonry joints).
- Where the barrier is composed of horizontal and vertical members and the distance between the tops of the horizontal members is less than 45 inches:
  - the horizontal members must be located on the swimming pool side of the fence;
  - the spacing between vertical members cannot exceed 1.75 inches; and
  - the spacing within any decorative cutouts in vertical members cannot exceed 1.75 inches. See Figure 3109.4.1.3 below.

- Where the barrier is composed of horizontal and vertical members and the distance between the tops of the horizontal members is 45 inches or more:
  - the spacing between vertical members cannot exceed 4 inches; and
  - the spacing within any decorative cutouts in vertical members cannot exceed 1.75 inches. See Figure 3109.4.1.3 below.

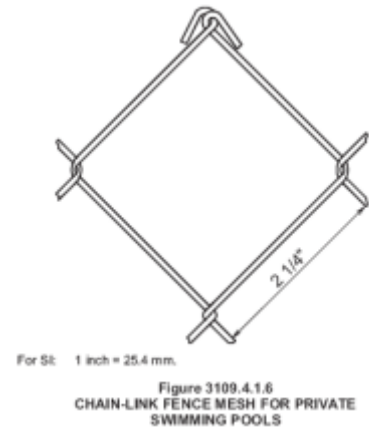
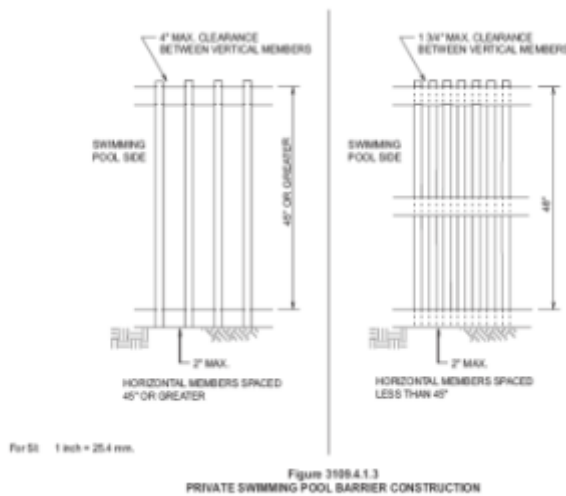

The figures on this page appear with the permission of the International Code Council. These figures may not be reproduced without the express written consent of the International Code Council.

- If a chain link fence is used as the barrier, the mesh size cannot exceed 2.25-inch square unless the fence is provided with slats fastened at the top or the bottom which reduce the openings to not more than 1.75 inches. See Figure 3109.4.1.6 above.
- Where the barrier is composed of diagonal members, such as a lattice fence, the opening formed by the diagonal members cannot exceed 1.75 inches.
- Access gates must satisfy the requirements stated above, and with the following additional requirements:
  - All gates must be self-closing.
    - In addition, if the gate is a pedestrian access gate, the gate must open outward, away from the pool.
  - All gates shall be self-latching, with the latch handle located within the enclosure (i.e., on the pool side of the enclosure) and at least 40 inches (1016 mm) above grade.
    - In addition, if the latch handle is located less than 54 inches (1372 mm) from the bottom of the gate, the latch handle shall be located at least 3 inches (76 mm) below the top of the gate, and neither the gate nor the barrier shall have any opening greater than 0.5 inch (12.7 mm) within 18 inches (457 mm) of the latch handle.
  - All gates shall be securely locked with a key, combination or other child proof lock sufficient to prevent access to the swimming pool through such gate when the swimming pool is not in use or supervised.
- A building wall can form part of the required barrier. However, where a wall of a dwelling serves as part of the barrier, at least one of the following requirements must be satisfied:
  - the pool must be equipped with a powered safety cover in compliance with reference standard ASTM F1346, entitled Standard Performance Specification for Safety Covers and Labeling Requirements for All Covers for Swimming Pools, Spas and Hot Tubs; or
  - all doors with direct access to the pool through that wall must be equipped with an alarm which:
    1. produces an audible warning when the door and its screen, if present, are opened,
    2. sounds continuously for a minimum of 30 seconds immediately after the door is opened,
    3. is capable of being heard throughout the house during normal household activities,
    4. automatically resets under all conditions, and
    5. is equipped with a manual means, such as touchpad or switch, to deactivate the alarm temporarily for a

- single opening (such deactivation cannot last for more than 15 seconds, and the deactivation switch[es] must be located at least 54 inches above the threshold of the door); or
  - o other means of protection, such as self-closing doors with self-latching devices, which are approved by the governing body and which afford a degree of protection not less than the protection afforded by the powered safety cover and door alarm described above, must be provided.
- In the case of an above-ground pool, the pool structure itself can serve as a part of the required barrier, provided that the pool structure is sufficiently rigid to obstruct access to the pool. However, where an above-ground pool structure is used as a barrier or where the barrier is mounted on top of the pool structure, and the means of access is a ladder or steps, then:
  - o the ladder or steps shall be capable of being secured, locked or removed to prevent access, or the ladder or steps shall be surrounded by a complying swimming pool barrier ;
  - o when the ladder or steps are secured, locked or removed, any opening created shall not allow the passage of a 4-inch-diameter sphere.
- Barriers shall be located so as to prohibit permanent structures, equipment or similar objects from being used to climb the barriers.

### **Barrier Requirements: Indoor Residential Swimming Pools**

All walls surrounding an indoor residential swimming pool must comply with the above-stated requirements for building walls used as all or part of a barrier around an outdoor residential swimming pool.

## **Entrapment Protection for Residential Swimming Pool and Spa Suction Outlets**

*According to the Consumer Products Safety Commission, there are an average of 283 drowning deaths and 2,700 emergency room visits related to swimming pools and spas involving children under the age of five each year. One cause of drowning deaths and injuries is entrapment. Entrapment occurs when a person becomes caught in the strong suction in and around swimming pool and spa drains. In some instances, the suction force around drains is so strong that the bather cannot break free and either drowns or is fatally injured before being rescued.*

### **Brief Summary of Requirements for Entrapment Protection for Residential Swimming Pool and Spa Suction Outlets:**

- Suction outlets must be designed to produce circulation throughout the pool or spa
- Single outlet systems, such as automatic vacuum cleaner systems, or other such multiple suction outlets whether isolated by valves or otherwise must be protected against user entrapment
- **Suction Fittings:** All pool and spa suction outlets (except surface skimmers) must be provided with:
  - o a cover that conforms with reference standard ANSI/ASME A112.19.8 *Suction Fittings for Use in Swimming Pools, Wading Pools, Spas, Hot Tubs, and Whirlpool Bathtub Appliances*, or
  - o a drain grate that is 18 inches x 23 inches or larger, or
  - o an approved channel drain system
- **Atmospheric vacuum relief system required:** All pool and spa single- or multiple-outlet circulation systems must be equipped with atmospheric vacuum relief should grate covers located in the pool become missing or broken
- The vacuum relief system needs to include at least one of the following two approved or engineered methods:
  1. Safety vacuum release system conforming to ASME A112.19.17; or
  2. An approved gravity drainage system
- **Dual drain separation:** Single or multiple pump circulation systems must have:
  - o at least two of the approved type of suction outlets, and

- a minimum horizontal or vertical distance of 3 feet between the outlets, and
  - the suction outlets piped so that water is drawn through them simultaneously through a vacuum-relief-protected line to the pump or pumps
- **Pool cleaner fittings:** Where provided, vacuum or pressure cleaner fittings shall be located in accessible positions at least 6 inches and not more than 12 inches below the minimum operational water level, or as an attachment to the skimmers
  - Flexible cord shall not exceed 3 feet in length. Cords that supply swimming pool equipment shall have a copper equipment grounding conductor not smaller than 12 AWG and shall terminate in a grounding-type attachment plug.

## Section E4203 – Equipment Location and Clearances

### **E4203.1 Receptacle Outlets:**

Receptacle outlets shall be installed and located in accordance with Sections E4203.1.1 through E4203.1.5. Distances shall be measured as the shortest path that an appliance supply cord connected to the receptacle would follow without penetrating a floor, wall, ceiling, doorway with hinged or sliding door, window opening, or other effective permanent barrier.

#### **E4203.1.1 Location:**

Receptacles that provide power for water-pump motors or other loads directly related to the circulation and sanitation system shall be permitted to be located between 6 feet and 10 feet from the inside walls of pools and outdoor spas and hot tubs, where the receptacle is single and of the grounding type and protected by ground-fault circuit interrupters (GFCI)

#### **E4203.1.2 Where Required:**

At least one 125-volt, 15 or 20-ampere receptacle supplied by a general-purpose branch circuit shall be located a minimum of 6 feet from and not more than 20 feet from the inside wall of pools and outdoor spas and hot tubs. This receptacle shall be located not more than 6 feet, 6 inches above the floor, platform or grade level serving the pool, spa or hot tub.

#### **E4203.1.3 GFCI Protection:**

All 15- and 20-ampere, single phase, 125 volt receptacles located within 20 feet of the inside walls of pools and outdoor spas and hot tubs shall be protected by a ground-fault circuit-interrupter. Outlets supplying pool pump motors supplies from branch circuits rated at 120 volts through 240 volts, single phase, whether by receptacle or direct connection, shall be provided with ground-fault circuit-interrupter protection for personnel.

#### **E4203.1.4 Indoor Locations:**

Receptacles shall be located not less than 6 feet from the inside walls of indoor spas and hot tubs. A minimum of one 125-volt receptacle shall be located between 6 feet and 10 feet from the inside walls of indoor spas or hot tubs.

#### **E4203.1.5 Indoor GFCI Protection:**

All 125-volt receptacles rated 30 amperes or less and located within 10 feet of the inside walls of spas and hot tubs installed indoors, shall be protected by ground-fault circuit-interrupters.